

Radio Powr Savr™ Wireless Daylight Sensor

Lutron's wireless daylight sensor is a battery-powered sensor that automatically controls lights via RF communication to compatible dimming or switching devices. This sensor mounts to the ceiling and measures light in the space. The sensor then wirelessly transmits the light level to the associated dimming or switching devices that automatically control the lights to balance light level in the space. The sensor combines both convenience and exceptional energy savings potential along with ease of installation.

Features

- Wireless daylight sensor has simple calibration.
- Daylight compensation through Lutron's reliable open loop control.
- Designed to give a linear response to changes in viewed light level.
- Light range 0–107,000 Lux (0–10,000 fc).
- Uses ClearConnect™ technology.
- Works seamlessly with Radio Powr Savr™ occupancy sensors and Pico® wireless controls.
- One sensor can be associated to up to 10 compatible RF dimming and switching devices allowing for switching, stepped dimming, and continuous dimming of multiple zones.
- Intuitive test mode provides instant system verification.
- Multiple ceiling mount methods available for different ceiling materials.
- Front accessible test buttons make setup easy.
- 10-year battery life.
- RoHS compliant.



Model Number

LRFX-DCRB-WH

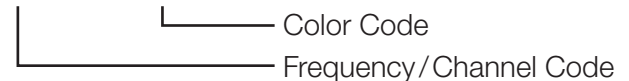

Frequency/Channel Codes

- 2** = 431.0 – 437.0 MHz (US, Canada, Mexico, Brazil)
- 3** = 868.125 – 869.850 MHz (Europe and UAE)
- 4** = 868.125 – 868.475 MHz (China and Singapore)
- 5** = 865.5 – 866.5 MHz (India)
- 6** = 312.3 – 314.8 MHz (Japan)
- 7** = 433.05 – 434.79 MHz (Hong Kong)

Color Code

WH = White

Compatible RF Devices

- For use with Lutron® products only
 - Communicates to various wireless Lutron® systems*
- * *Contact Lutron® Customer Service at www.lutron.com for frequency/channel code compatibility with your particular geographic region, and for integrating with other Lutron® lighting and shading products.*

| | |
|-------------|----------------|
| Job Name: | Model Numbers: |
| Job Number: | |

Specifications

Regulatory

Lutron® Quality Systems Registered to ISO 9001:2008

Standards

LRF2-

- FCC certified
- IC certified
- COFETEL
- ANATEL
- ASEP
- CRC
- SUBTEL
- SUPERTEL
- SUTEL
- Meets CA (U.S.A.) Energy Commission Title 24 requirements

LRF3-

- CE Marked (European Union)
- TRA Type Approved (United Arab Emirates)

LRF4-

- SRRC Type Approved (Mainland China)
- iDA Registered (Singapore)

LRF5-

- WPC Type Approved (India)

LRF6-

-  007YUUL0688

LRF7-

- FCC certified

Power/Performance

- Operating voltage: 3 V_{DC}
- Operating current: 7 µA
- Requires one CR 2450 lithium battery
- 10-year battery life
- Non-volatile memory (settings are stored during power loss)

Environment

- Temperature: 32 °F to 104 °F (0 °C to 40 °C)
- For indoor use only
- Relative humidity: < 90% non-condensing

Range

- **LRF2, LRF3, LRF4, LRF5, LRF7**
Local load controls must be located within 60 ft (18 m) line of sight, or 30 ft (9 m), through walls, of a sensor.
- **LRF6**
Local load controls must be located within 23 ft (7 m), through walls, of a sensor.

Dimensions

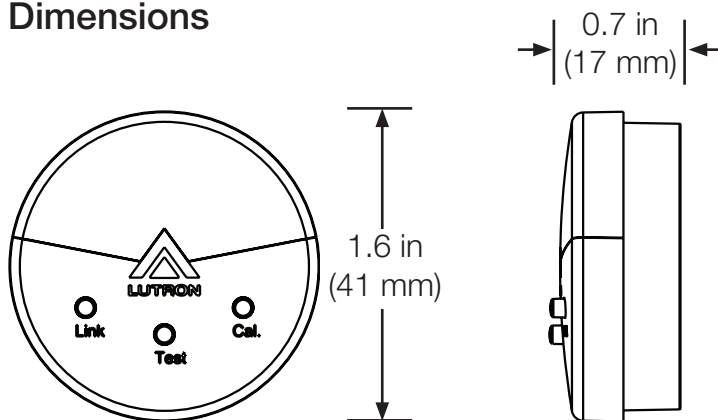

| | |
|-------------|----------------|
| Job Name: | Model Numbers: |
| Job Number: | |

Mounting

Location for average size areas

Arrow points towards the area viewed by the sensor (towards windows).

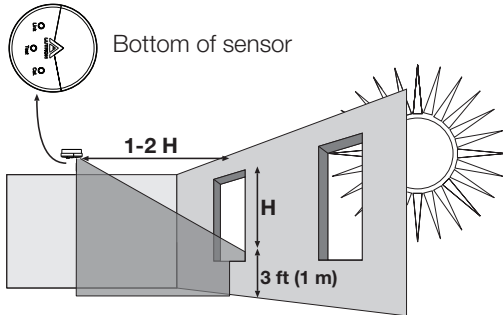

H = Effective Window Height

Location for narrow areas (corridors, private offices)

Arrow points towards the area viewed by the sensor (away from window)

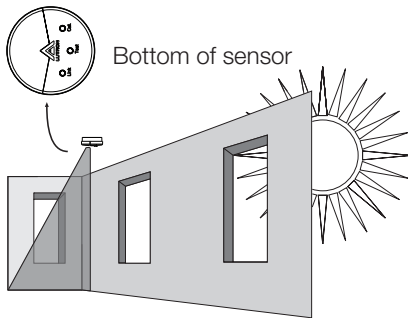

Installation Overview

Determine the Daylight Sensor mounting location using the diagrams at left:

- The arrow on the daylight sensor points toward the area viewed by the sensor.
- Place the daylight sensor so its arrow is pointed at the nearest window at a distance from the window of one to two times the effective window height (H).
- The effective window height (H) starts at the window sill or 3 ft (1 m) up from the floor, whichever is higher, and ends at the top of the window.
- Ensure that the view of the daylight sensor is not obstructed (e.g. ceiling fans or pendant fixtures).
- Do not position the daylight sensor above an electric light that shines up at the ceiling or at the sensor.
- Do not position the daylight sensor in the well of a skylight or above indirect lighting fixtures.
- For narrow areas where the daylight sensor cannot be placed 1-2 (H) from windows, place sensor near windows facing into the space.
- Mount Sensor(s) away from large metal surfaces (e.g. light fixtures or metal-backed ceiling tiles). Metal objects will affect the Sensor's RF performance.

Daylight Sensor Communication

- A sensor can communicate with up to 10 local load devices.
- A local load device or zone can receive information from only one daylight sensor.

| | |
|-------------|----------------|
| Job Name: | Model Numbers: |
| Job Number: | |